

HYUNDAI
POWER PRODUCTS

ELECTRIC LOG SPLITTER

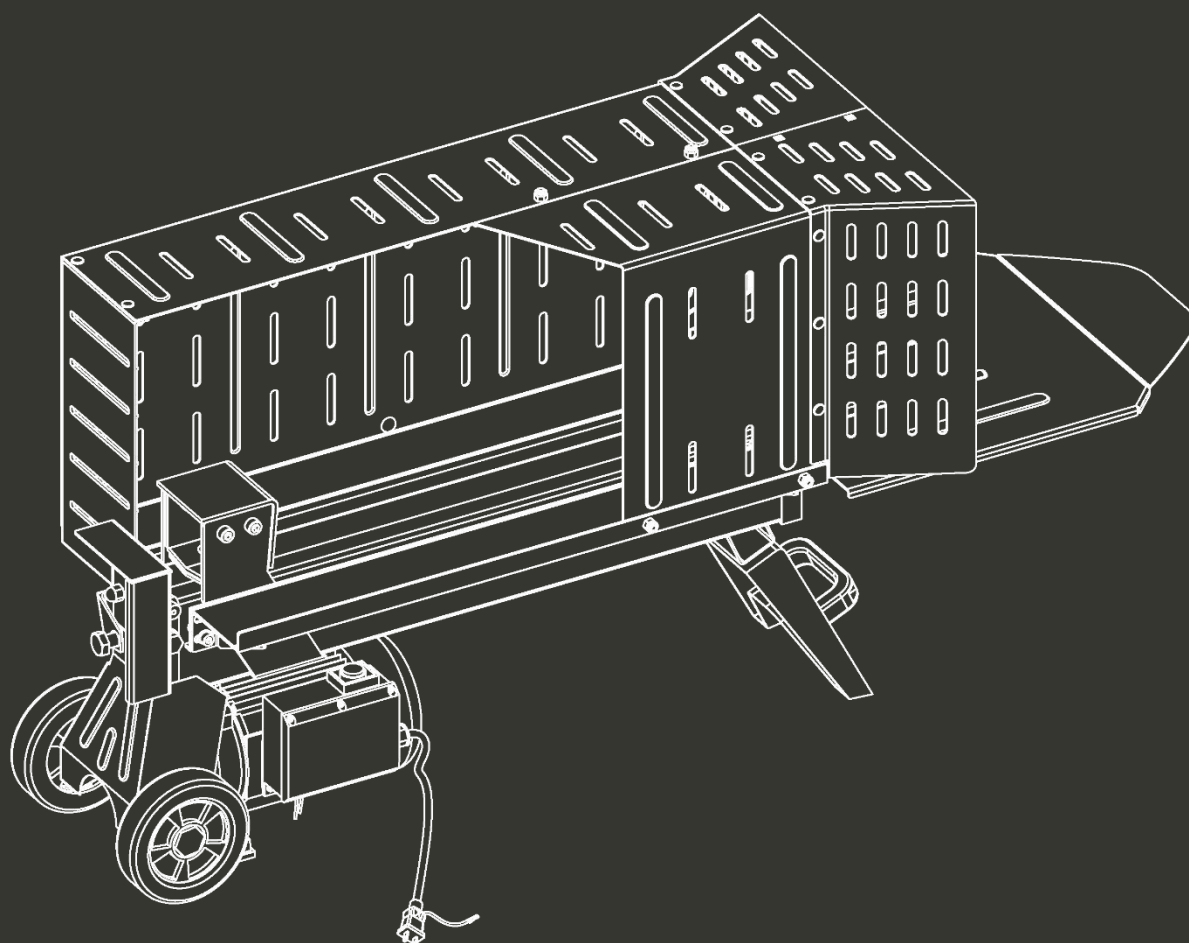



HFBE525T

ORIGINAL INSTRUCTIONS



WARNING: Read thoroughly the instruction manual before use.

SAFETY WARNINGS & CAUTIONS

SAFETY WARNINGS & INSTRUCTIONS	SYMBOL AFFIXED TO THE MACHINE
<ul style="list-style-type: none">● UNDERSTAND YOUR LOG SPLITTER Read and understand the owner's manual and labels affixed to the log splitter. Learn its application and limitations as well as the specific potential hazards peculiar to it.● DRUGS, ALCOHOL AND MEDICATION Do not operate the log splitter while under the influence of drugs, alcohol, or any medication that could affect your ability to use it properly.● AVOID DANGEROUS CONDITIONS Put the log splitter on a high, stable, flat, and level work bench where there is plenty of room for handling, and help the operator stay alert. Bolt the log splitter to the work surface if it tends to slip, walk, or slide. The height of the worktable must be between 850-1650mm Keep your work area clean and well lighted. Cluttered areas invites injuries. Do not use the log splitter in wet or damp areas or expose it to rain. Do not use it in areas where fumes from paint, solvents or flammable liquids pose a potential hazard.	
<ul style="list-style-type: none">● INSPECT YOUR LOG SPLITTER Check your log splitter before turning it on. Keep guards in place and in working order. Form a habit of checking to see that keys and adjusting wrenches are removed from tool area before turning it on. Replace damaged, missing or failed parts before using it.	
<ul style="list-style-type: none">● DRESS PROPERLY Do not wear loose clothing, gloves, neckties or jewelry (rings, wrist watches). They can be caught in moving parts. Protective electrically non conductive gloves and non-skid footwear are recommended when working. Wear protective hair covering to contain long hair, preventing it from get caught in machinery.	
<ul style="list-style-type: none">● PROTECT YOUR EYES AND FACE Any log splitter may throw foreign objects into the eyes. This can cause permanent eye damage. Always wear safety goggles. Everyday eyeglasses have only impact resistant lenses. They are not safety glasses. Do not put the log splitter on the ground for operations. This is awkward operating position that the operator has to bring his face	

close to the machine, and thus risks being struck by wood chips or debris.

● EXTENSION CORDS

Improper use of extension cords may cause inefficient operation of the log splitter which can result in overheating. Be sure the extension cord is no longer than 10m and its section is no less than 2.5mm² to allow sufficient current flow to the motor.

Avoid use of free and inadequately insulated connections. Connections must be made with protected material suitable for outdoor use.

● AVOID ELECTRICAL SHOCK

Check that the electric circuit is adequately protected and that it corresponds with the power, voltage and frequency of the motor. Check that there is a ground connection, and a regulation differential switch upstream.

Ground the log splitter. Prevent body contact with grounded surfaces: pipes, radiators, ranges, and refrigerator enclosures.

Never open the pushbutton box on the motor. Should this be necessary, contact a qualified electrician.

Mark sure your fingers do not touch the plug's metal prongs when plugging or unplugging the log splitter.

● KEEP VISITORS AND CHILDREN AWAY

The log splitter must be always operated by one person only. Other people should keep a safe distance from the work area, especially when the log splitter is under operations. Never use another people to help you with freeing jammed log.

● INSPECT YOUR LOG

Make sure there are no nails or foreign objects in logs to be split. The ends of the logs must be cut square. Branches must be cut of flush with the trunk.

● DON'T OVERREACH

Floor must not be slippery.

Keep proper footing and balance at all times.

Never stand on log splitter. Serious injury could occur if the tool is tipped or if the cutting tools is unintentionally contacted. Do not store anything above or near the log splitter where anyone might stand on the tool to reach them.

● AVOID INJURY FROM UNEXPECTED ACCIDENT

Always pay full attention to the movement of the log pusher.

Do not attempt to load the log on until the log pusher has stopped.

Keep hands out of the way of all moving parts.

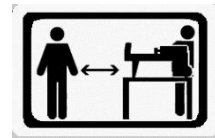

● PROTECT YOUR HANDS

Keep your hands away from splits and cracks which open in the log; They may close suddenly and crush or amputate your hands. Do not remove jammed logs with your hands.



● DON'T FORCE TOOL

It will do a better and safer job at its design rate. Never try to split logs larger than those indicated in the specifications table. This could be dangerous and may damage the machine.

Don't use log splitter for a purpose for which it was not intended.

● NEVER LEAVE TOOL RUNNING UNATTENDED

Don't leave tool until it has come to a complete stop.

● DISCONNECT POWER

Unplug when not in use, before making adjustments, changing parts, cleaning, or working on the log splitter; Consult technical manual before servicing.

● PROTECT THE ENVIRONMENT

Take used oil to an authorized collection point or follow the stipulations in the country where the log splitter is used.

Do not discharge into drains, soil or water.

● MAINTAIN YOUR LOG SPLITTER WITH CARE

Keep the log splitter clean for best and safest performance.

● MAKE THE WORKSHOP CHILDPROOF

Lock the shop. Disconnect master switches. Store the log splitter away from children and others not qualified to use it.



- Operator must receive necessary training and instruction from a qualified person before handling the tool.
- Use the tool only for the intended use. Misuse (such as using material other than log) can damage the tool and cause accidents and injuries.
- The splitting operation of the machine is designed to be activated by one person. While there is the possibility that additional operators could be working with the machine (e.g. for loading and unloading), only one operator should activate splitting operations.
- The machine shall not be used by children.
- Wear suitable personal protective equipment (PPE), including safety footwear, close fitting clothing and suitable work gloves, eye protection and hearing protection.
- Before starting work, hydraulic pipes and hoses shall be inspected and the stopping devices shall be tested.
- Tests of the machine's safety devices before use the tool. If safety devices do not work properly, do not use the tool and bring it to a qualified technician for inspection and repair.
- The working area shall be free from obstructions; before installation and operation, clear the working area. Keep the working area free from obstructions, e.g. logs, split wood, etc.

- Do not leave the machine unattended when running;
- Do not reach into the splitting zone;

Symbols



Wear hearing protection



The machine must be operated only by one person



Do not smoke



Warning: Risk of slipping



Warning: Floor-level obstacle



Do not take the wood by hand if the wood gets stuck



Warning: Electricity. Risk of electrical shock

APPLICATION CONDITIONS

This log splitter is a home use model. It is designed for operating under ambient temperatures between +5°C and 40°C and for installation at altitudes no more than 1000m above M.S.L. The surrounding humidity should be less than 50% at 40°C. It can be stored or transported under ambient temperatures between -25°C and 55°C.

This machine must be used and fixed on a suitable work table to comply with the height of the control actuators between 850-1650mm from the ground.

SPECIFICATIONS

Model Number		HFBE525T			
Motor		230V~	50Hz	1500W	S3 50% IP54
Log Capacity	Diameter	5 - 25cm			
	Length	52cm			
Splitting Force		5T			
Hydraulic Pressure		20Mpa			
Hydraulic Oil Capacity		3.3L			
Overall Size	Length	1360mm			
	Width	480mm			
	Height	670mm			
Weight		59kg			
Operating speed		2800min ⁻¹			

The diameter of the log is indicative – a small log can be difficult to split when it has knots or a particularly tough fiber. On the other hand, it may not be difficult to split logs with regular fibers even if its diameter exceeds the max. figure indicated above.

ELECTRICAL REQUIREMENTS

Connect the main leads to a standard 230V \pm 10% (50Hz \pm 1Hz) electrical supply which has protection devices of under-voltage, over-voltage, over-current as well as a residual current device (RCD) which maximum residual current rated at 0.03A.

TRANSPORTING THE WOODEN SPLITTER TO THE PLACE OF WORK

The log splitter is equipped with 2 wheels for minor displacements. To move the log splitter to your workplace, roll log splitter at a slight angle after making sure the oil tank cap is tight. Do not lift or carry the log splitter to move it.

SET UP AND PREPARATION FOR OPERATION

1. Log Pusher
2. Work Table
3. Shield
4. Support Leg
5. Switch
6. Motor
7. Pushbutton Box
8. Wheels for Minor Moving ONLY.
9. Hydraulic Control Lever.
10. Control Lever Guard
13. Bleed Screw
14. Oil Drain Bolt with Dipstick

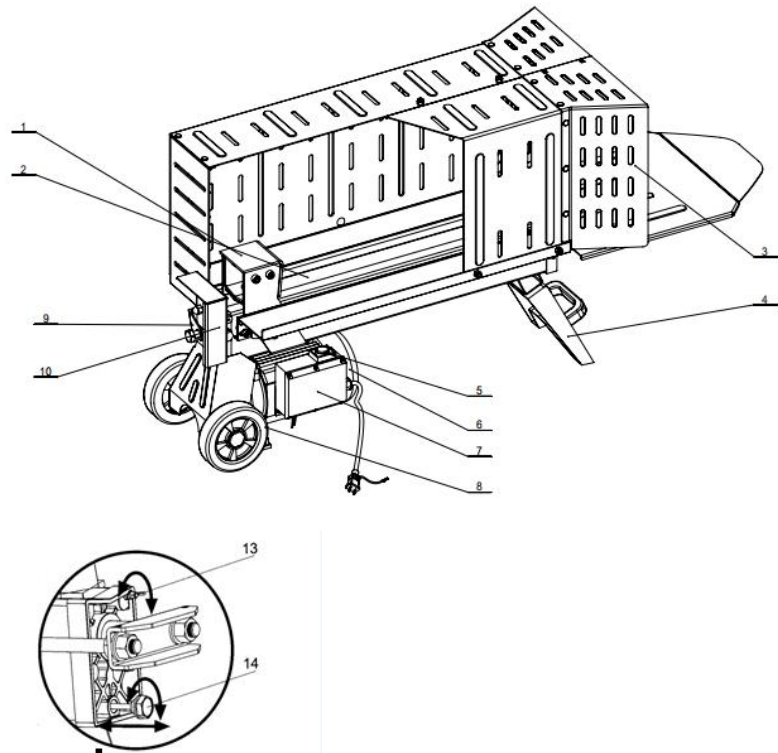

Installation

- 1) Install the foot and foot grip under the machine, and secure with screws, seals and bolts.
- 2) Install the support plate on the machine by hooking the hooks under the supports provided for this purpose.
- 3) Install the work plates on both sides of the machine, align the holes, put the seals and screws to secure the parts.
- 4) Install the left cover on the machine (it must be aligned with the holes in the worktable), and secure with the M8 hex bolts and M8 seals.
- 5) Install the cover and secure with M8 hex bolts and M8 seals.
- 6) Install the M8 square-head bolts through the left and right cover installation holes and the connection plate and tighten the four M8 nuts.
- 7) Install the protective covers on the front of the unit and the rear cover on the back of the machine. Carefully push the fasteners into the installation holes of the protective covers and the rear cover, then carefully insert the fasteners into the mounting holes in the right and left covers.

Before operating the log splitter, the Bleed Screw should be loosened by some rotations until air can go in and out of the oil tank smoothly.

Air flow thru the Bleed Screw hole should be detectable during the log splitter is under operations.

Before moving the log splitter, make sure the Bleed Screw is tightened to avoid oil leaking from this point.



FAILED TO LOOSEN THE BLEED SCREW WILL KEEP THE SEALED AIR IN HYDRAULIC SYSTEM BEING COMPRESSED AFTER BEING DECOMPRESSED. SUCH CONTINUOUS AIR COMPRESSION AND DECOMPRESSION WILL BLOW OUT THE SEALS OF THE HYDRAULIC SYSTEM AND CAUSE PERMANT DAMAGE TO THE LOG SPLITTER.

15. Max Pressure Limiting Screw



DO NOT ADJUST THE MAX PRESSURE LIMITING SCREW!

Max pressure was set before the log splitter ex work and the max pressure limiting screw is sealed with glue to ensure the log splitter works under pressure no more than 5 tons. The setting was done by qualified mechanic with professional instruments.

Unauthorized resetting will cause the hydraulic pump fail to output enough splitting pressure or ***RESULT IN SERIOUS INJURY AS WELL AS DAMAGE TO THE MACHINE.***

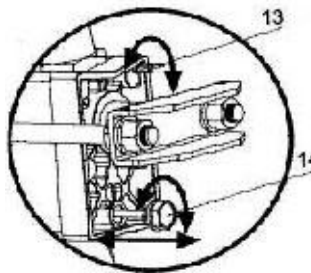

- Screw the handle and the foot with the 2 screws and the bolts, nuts, washers as below:



- Screw the 2 side plates together with 4 brackets and 4 nuts, bolts and washers



- Screw the side protections with 6 nuts and bolts and 3 nuts, bolts and washers as below:

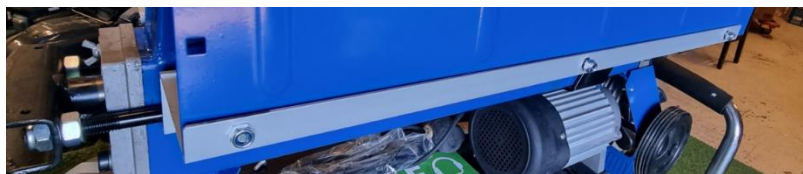



- Insert the tray extension by inserting the 2 hooks on the legs as below:



- Position the side plastic protections by inserting the 10 fixing clips by force

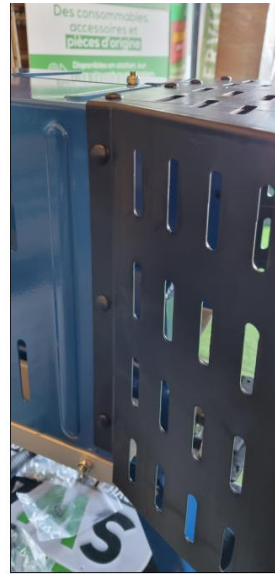

- Position the rear plastic protection by inserting the 5 fixing clips by force



WIRING DIAGRAM

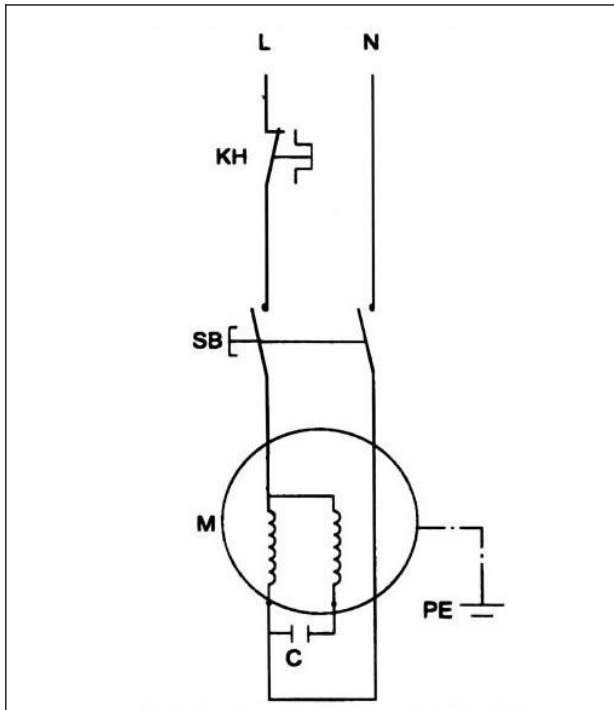

PLUMBING DIAGRAM

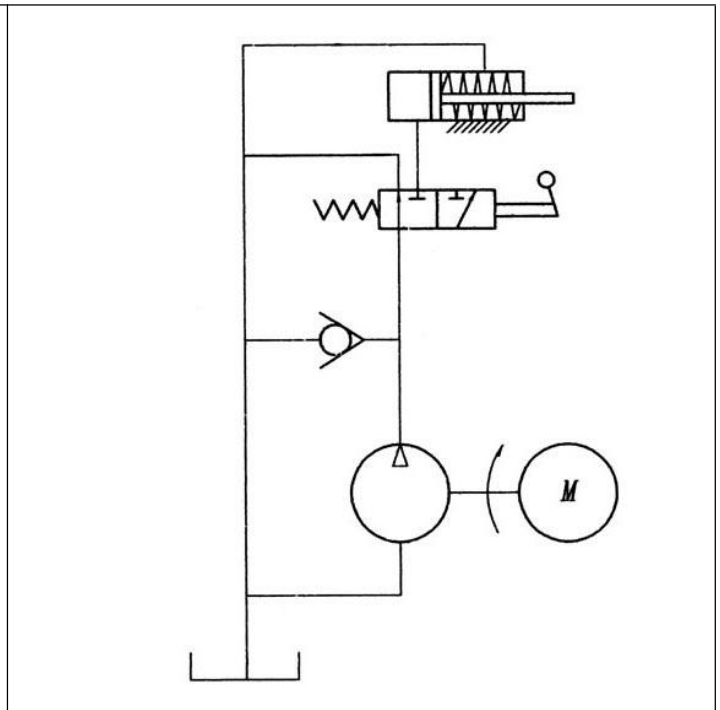

LOG SPLITTER OPERATION

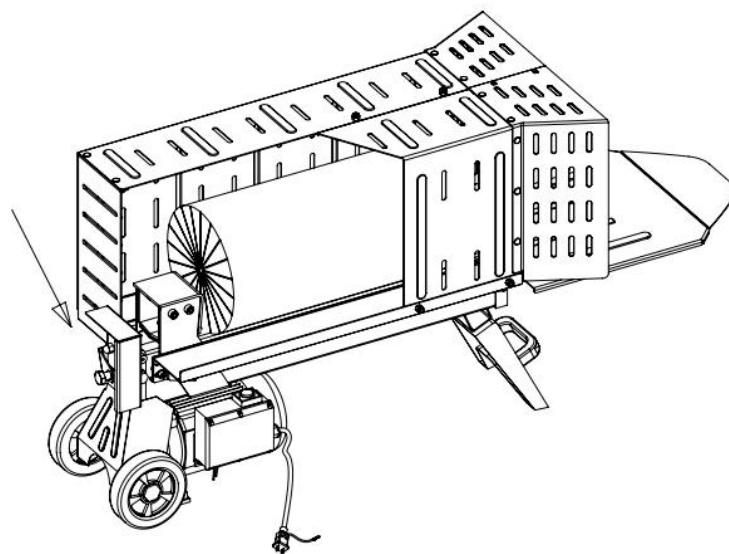

This log splitter is equipped with “ZHB” control system that requires to be operated by both hands of the user – Left hand controls the hydraulic control lever while right hand controls the pushbutton switch. The log splitter will freeze upon absence of either hand. Only after both hands release the controls, the log pusher starts to return backward to the starting position.

Before the job, the splitter should be placed on the platform 850mm minimum above the ground, as shown in the figure below

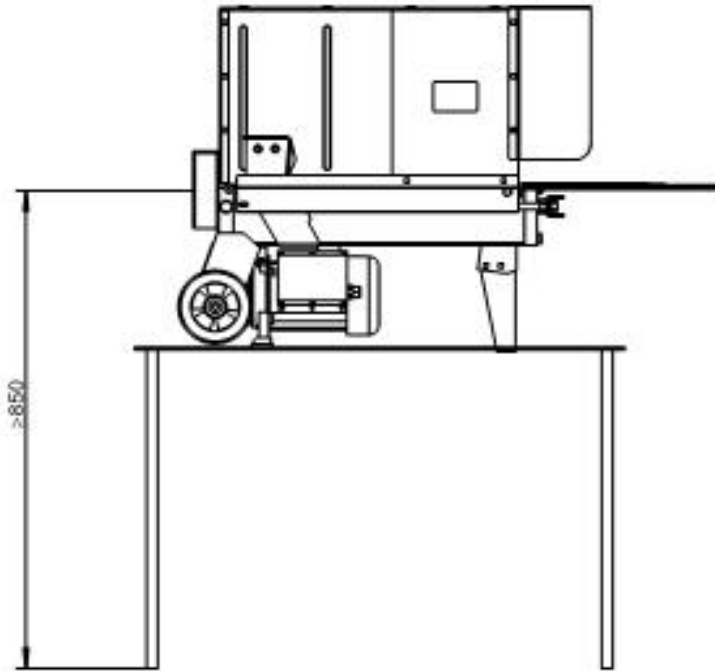

Trigger type lock-out device is adopted to avoid accidental Hydraulic Control Lever pushdown. To operate the Hydraulic Control Lever, draw the Trigger backward with the index finger before push the Hydraulic Control Lever forward.



Never force the log splitter for more than 5 seconds by keeping pressure on it to split excessively hard wood.

After this time interval, the oil under pressure will be overheated and the machine could be damaged. For such extremely hard log, rotate it by 90° to see whether it can be split in a different direction. In any case, if you are not able to split the log, this means that its hardness exceeds the capacity of the machine and thus that log should be discarded to protect the log splitter.

Always set logs firmly on the log retaining plates and work table. Make sure logs will not twist, rock or slip while being split. Do not force the blade by splitting the log on the upper part. This will break the blade or damage the machine.

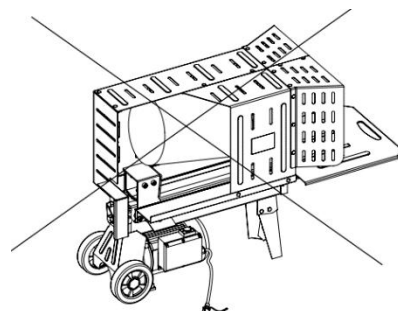

Break log in the direction of its growing grain. Do not place log across the log splitter for splitting. It may be dangerous and may seriously damage the machine.

Do not attempt to split 2 pieces of logs at the same time. One of them may fly up and hit you.

FREEING A JAMMED LOG

- Release both controls.
- After the log pusher moves back and completely stops at its starting position, insert a wedge wood under the jammed log.
- Start the log splitter to push the wedge wood to go completely under the jammed one.
- Repeat above procedure with sharper slope wedge woods until the log is completely freed.

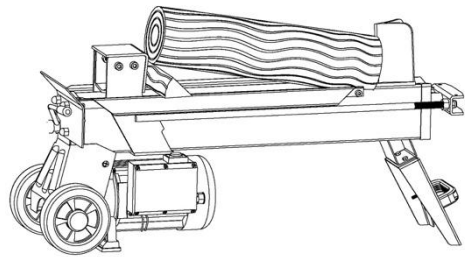

**Do not try to knock the jammed log off,
Knocking about will damage the machine
or may launch the log and cause accident.**

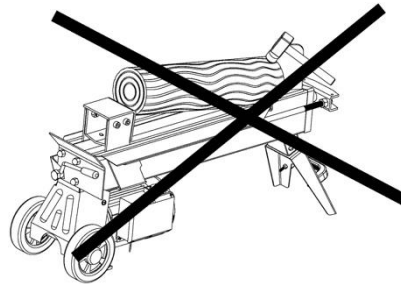

MAINTENANCE

REPLACING HYDRAULIC OIL

Replace the Hydraulic oil in the log splitter after every 150 hours of use. Take following steps to replace it.

- Make sure all moving parts stops and the log splitter is unplugged.
- Unscrew Oil Drain Bolt with Dipstick to remove it.
- Turn the log splitter on the Support Leg side over a 4 liters capacity container to drain the hydraulic oil off.
- Turn the log splitter on the the motor side.
- Refill fresh hydraulic oil at the volume as per the hydraulic oil capacity of a particular model indicated in above specifications table.
- Clean the surface of Dipstick on the Oil Drain Bolt and put it back into the oil tank while keep the log splitter vertically.
- Make sure the level of the refilled oil is just between 2 grooves around the Dipstick.
- Clean the Oil Drain Bolt before thread them back. Make sure they are tightened to avoid leakage before place the log splitter horizontally.

Periodically check oil level to ensure it is between 2 grooves around the Dipstick. Upon Lower oil level, oil refilling is required.

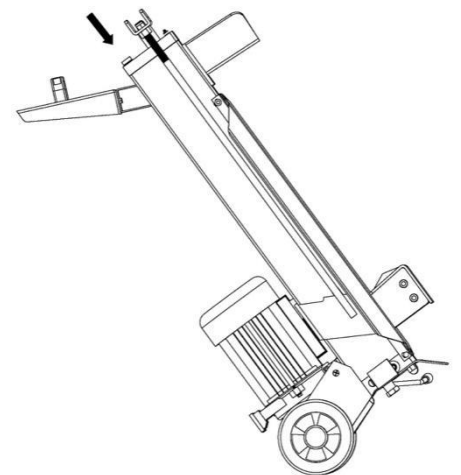
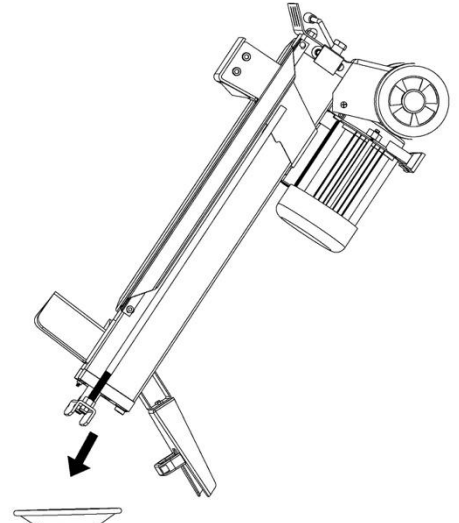

Following hydraulic oils or equivalent are recommend for the log splitter's hydraulic transmission system:

SHELL Tellus 22

MOBIL DTE 11

ARAL Vitam GF 22

BP Energol HLP-HM 22

SHARPENING WEDGE

After using the log splitters for some time, sharpen the wedge of the log splitter using a fine-toothed file and smooth any burrs or crushed area along the cutting edge.

TROUBLE SHOOTING

PROBLEM	PROBABLE CAUSE	REMEDY SUGGESTED
Motor Stops to Start	Overload Protection Device disengaged to protect the log splitter from being damaged	Contact a qualified Electrician for opening the Pushbutton Box to engage the Overload Protection Device inside *
Fails to split logs	Log is improperly positioned	Refer to “ Log Splitter Operation” section for perfect log loading.
	The sizes or hardness of the log exceeds the capacity of the machine	Reduce the log sizes before splitting it on the log splitter
	Wedge cutting edge is blunt	Refer to “ Sharpening Wedge “ section to sharpen the cutting edge.
	Oil leaks	Locate leak(s) and contact the dealer
	Unauthorized adjustment was made on Max. Pressure Limiting Screw. Lower max pressure rating was set.	Contact the dealer.
The log pusher moves jerkily, taking unfamiliar noise or vibrating a lot	Lack of hydraulic oil and excessive air in the hydraulic system.	Check oil level for possible oil refilling. Contact the dealer.
Oil leaks around cylinder ram or from other points.	Air sealed in hydraulic system while operating.	Loosen Bleed Screw by 3 ~ 4 rotations before operating the log splitter
	Bleed Screw is not tightened before moving the log splitter.	Tighten the Bleed Screw up before moving the log splitter.
	Oil Drain Bolt with Dipstick is not tight.	Tighten the Oil Drain Bolt with Dipstick.
	Hydraulic Control Valve Assembly and / or seal(s) worn	Contact the dealer



Electrical products should not be discarded with household products. According to the European Directive 2012/19/EU on waste electrical and electronic equipment and its implementation into national law, electrical products used must be collected separately and disposed of at collection points provided for this purpose. Talk with your local authorities or dealer for advice on recycling.

DECLARATION OF CONFORMITY

Declaration of conformity



BUILDER SAS

ZI, 32 rue Aristide Bergès – 31270 Cugnaux - France

Tel : +33 (0)5.34.502.502 Fax : +33 (0)5.34.502.503

Declare that the following machine

ELECTRIC LOG SPLITTER

HFBE525T

Serial number: 20221232946- 20221233050

Is in conformity with the Directive Machine 2006/42/EC and to the regulations transposing it;

Also in conformity with the European Directives:

A la Directive RoHS (EU)2015/863 amending 2011/65/EU

A la Directive EMC 2014/30/EU

Also in conformity with the following standards:

EN609-1:2017

EN60204-1:2006+A1:2009

EN 55014-1:2017/A11:2020

EN IEC 55014-1:2021

EN 55014-2:1997/A2:2008

EN IEC 55014-2:2021

EN 61000-3-2:2014

EN IEC 61000-3-2:2019/A1:2021

EN 61000-3-11:2000

Responsible of technical file: Olivier Patriarca

Cugnaux, 18/11/2022

Philippe MARIE / PDG

A handwritten signature in black ink, appearing to read 'Philippe Marie', is written over a faint, circular stamp or watermark.

HYUNDAI

WARRANTY

The manufacturer guarantees the product against defects in material and workmanship for a period of 2 years from the date of the original purchase. The warranty only applies if the product is for household use. The warranty does not cover breakdowns due to normal wear and tear.

The manufacturer agrees to replace parts identified as defective by the designated distributor. The manufacturer does not accept responsibility for the replacement of the machine, in whole or in part, and/or ensuing damage.

The warranty does not cover breakdowns due to:

- insufficient maintenance.
- abnormal assembly, adjustment or operations of the product.
- parts subject to normal wear and tear.

The warranty does not extend to:

- shipping and packaging costs.
- using the tool for a purpose other than that for which it was designed.
- the use and maintenance of the machine done in a manner not described in the user manual.

Due to our policy of continuous product improvement, we reserve the right to alter or change specifications without notice. Consequently, the product may be different from the information contained therein, but a modification will be undertaken without notice if it is recognized as an improvement of the preceding characteristic.

READ THE MANUAL CAREFULLY BEFORE USING THE MACHINE.

When ordering spare parts, please indicate the part number or code, you can find this in the spare parts list in this manual. Keep the purchase receipt; without it, the warranty is invalid. To help you with your product, we invite you to contact us by phone or via our website:

- **+33 (0)9.70.75.30.30**
- **<https://services.swap-europe.com/contact>**

You must create a "ticket" via the web platform.

- Register or create your account.
- Indicate the reference of the tool.
- Choose the subject of your request.
- Describe your problem.
- Attach these files: invoice or sales receipt, photo of the identification plate (serial number), photo of the part you need (for example: pins on the transformer plug which are broken).



PRODUCT FAILURE

WHAT TO DO IF MY MACHINE BREAKS DOWN?

If you bought your product in a store:

- a) Empty the fuel tank if your product has one..
 - b) Make sure that your machine is complete with all accessories supplied, and clean! If this is not the case, the repairer will refuse the machine.
- Go to the store with the complete machine and with the receipt or invoice.

If you bought your product on a website:

- a) Empty the fuel tank your product has one..
- b) Make sure that your machine is complete with all accessories supplied, and clean! If this is not the case, the repairer will refuse the machine.
- c) Create a SWAP-Europe service ticket on the site: <https://services.swap-europe.com> When making the request on SWAP-Europe, you must attach the invoice and the photo of the nameplate (serial number).
- d) Contact the repair station to make sure it is available before dropping off the machine.

Go to the repair station with the complete machine packed, accompanied by the purchase invoice and the station support sheet downloadable after the service request is completed on the SWAP-Europe site

For machines with engine failure from manufacturers BRIGGS & STRATTON, HONDA and RATO, please refer to the following instructions.

Repairs will be done by approved engine manufacturers of these manufacturers, see their site:

- <http://www.briggsandstratton.com/eu/fr>
- <http://www.honda-engines-eu.com/fr/service-network-page;jsessionid=5EE8456CF39CD572AA2AEEDFD290CDAE>
- <https://www.rato-europe.com/it/service-network>

Please keep your original packaging to allow for after-sales service returns or pack your machine with a similar cardboard box of the same dimensions.

For any question concerning our after-sales service you can make a request on our website <https://services.swap-europe.com>

Our hotline remains available at +33 (9) 70 75 30 30.



WARRANTY EXCLUSIONS

THE WARRANTY DOES NOT COVER:

- Start-up and setting up of the product.
- Damage resulting from normal wear and tear of the product.
- Damage resulting from improper use of the product.
- Damage resulting from assembly or start-up not in accordance with the user manual.
- Breakdowns related to carburetion beyond 90 days and fouling of carburetors.
- Periodic and standard maintenance events.
- Actions of modification and dismantling that directly void the warranty.
- Products whose original authentication marking (brand, serial number) has been degraded, altered or withdrawn.
- Replacement of consumables.
- The use of non-original parts.
- Breakage of parts following impacts or projections.
- Accessories breakdowns.
- Defects and their consequences linked to any external cause.
- Loss of components and loss due to insufficient screwing.
- Cutting components and any damage related to the loosening of parts.
- Overload or overheating.
- Poor power supply quality: faulty voltage, voltage error, etc.
- Damages resulting from the deprivation of enjoyment of the product during the time necessary for repairs and more generally the costs related to the immobilization of the product.
- The costs of a second opinion established by a third party following an estimate by a SWAP-Europe repair station
- The use of a product which would show a defect or a breakage which was not the subject of an immediate report and/or repair with the services of SWAP-Europe.
- Deterioration linked to transport and storage*.
- Launchers beyond 90 days.
- Oil, petrol, grease.
- Damages related to the use of non-compliant fuels or lubricants.

* In accordance with transport legislation, damage related to transport must be declared to carriers within 48 hours maximum after observation by registered letter with acknowledgement of receipt.

This document is a supplement to your notice, a non-exhaustive list.

Attention: all orders must be checked in the presence of the delivery person. In case of refusal by the delivery person, it you must simply refuse the delivery and notify your refusal.

Reminder: the reserves do not exclude the notification by registered letter with acknowledgement within 72 hours.

Information:

Thermal devices must be wintered each season (service available on the SWAP-Europe site). Batteries must be charged before being stored.

HYUNDAI
POWER PRODUCTS

For Inquiries, please contact:

BUILDER SAS
32, Rue Aristide Bergès Z1 31270 Cugnaux, France
Tél.: +33(0)5.34.502.502 Fax : +33(0)5.34.502.503
<http://www.hyundaipower-fr.com/>
Fabriqué en République Populaire de Chine(PRC)